

StyloW

Touch...the sky!

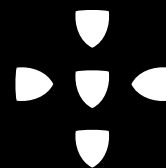



Made in Europe

Multimedia Kiosks and Digital Mupis are developed and produced in Portugal.

The success of our company in the international market shows us that we have developed and produce excellent products and we should therefore be proud and confident in the future.



The StyloW Model was developed specifically for indoor use, particularly for placing in walls.

This model is manufactured in stainless steel AISI304 or painted steel (RAL Colors) using steel plate of 1,5mm to 2,5mm which ensures the stability and rigidity of all structure.

The area where the computer is installed and possible peripherals (card readers, coin acceptors, etc.), is protected with access through a security lock and includes three power plugs.

On top of display are two integrated speakers that fits smoothly in the all structure.

Multi touch **Functionality**

The StyloW Model is normally equipped with a 32" display (19", 22" or other sizes are possible).

StyloW can be equipped with computers with different "performances" (CPU) with hard drives from 100 to 320 GB, 4 Gb Ram Memory, 128mb graphics card expandable to 512, 10/100 mb ethernet, and Windows 7 or 8. This kiosk can also be equipped with computers with other OS like Linux, etc.

StyloW

Interactivity with dimension

Dimensions of the kiosk

for 32" display



H 550 W 950 D 120mm
(for 32" display)



Weight 20 kg



Everything has been planned down to the smallest detail. The "clean" and round lines give you an elegance unprecedented in the field of multimedia kiosks wall.

The metal frame has also been designed to be as narrow as possible, in order to highlight only the display.

► The dimensions and specifications are given in graphical representation and may not correspond to the reality of the equipment. The dimensions shown are approximate and represent the equipment for a certain size display. The final dimension may vary depending on the display model and other components used. The client must request technical drawings for final validation (measures and specifications).

StyloW

Many Functionalities



StyloW Portrait

The StyloW can be equipped with displays of various sizes and with various types of touch or multitouch technology.

It is possible to define the orientation of the kiosk in horizontal, vertical or table.

StyloW Landscape

The StyloW can be equipped with displays of various sizes and with various types of touch or multitouch technology.

It is possible to define the orientation of the kiosk in horizontal, vertical or table.



StyloW

Many Functionalities



Wall



Printer
Webcam



Interactive
Table



Floor
stand



keyboard

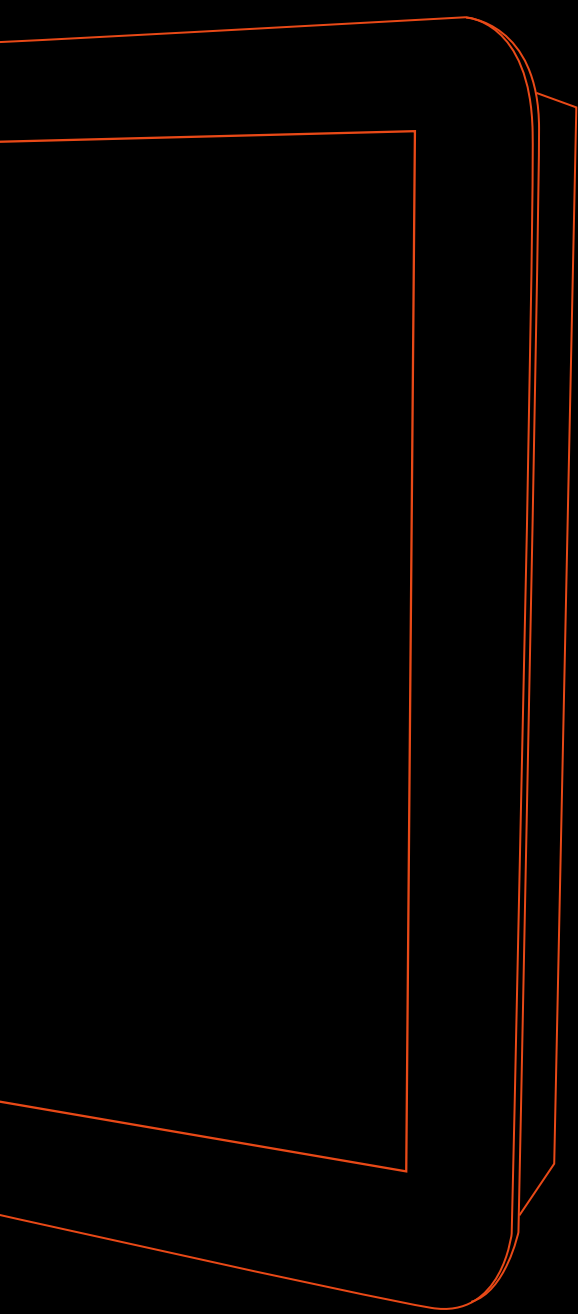

Technical Specifications



StyloW

Distance comparison and main features

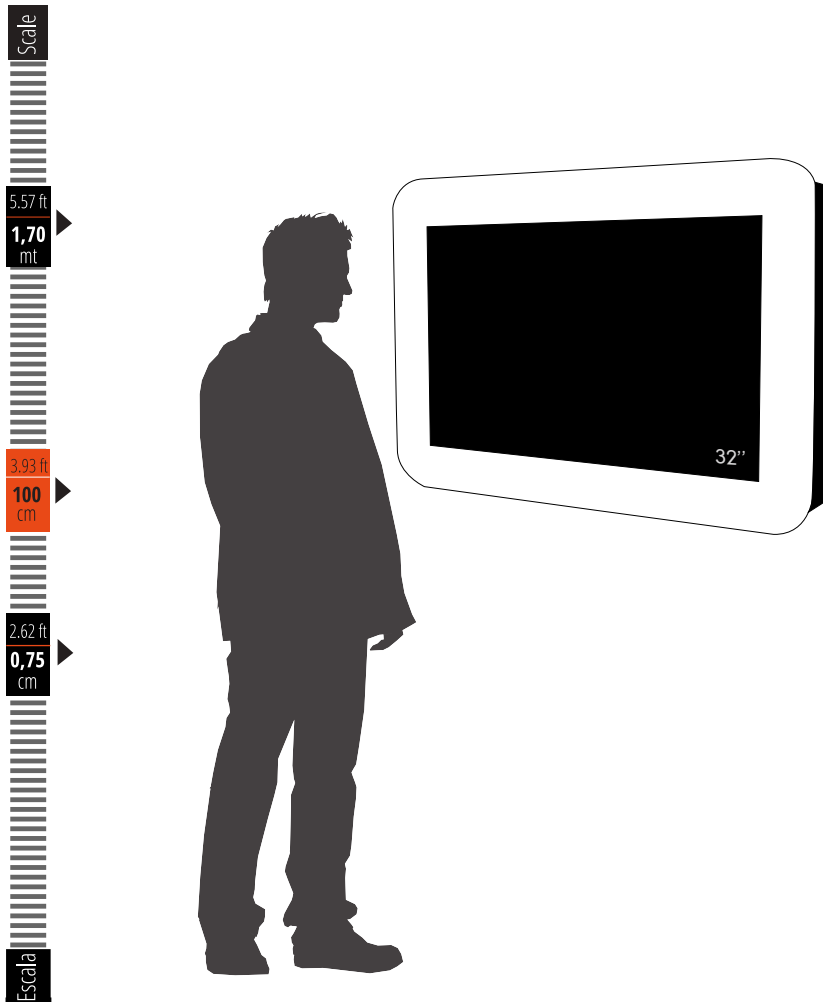

General Characteristics

Type

- Indoor
- Outdoor

Materials

- Painted Steel
- Stainless Steel
- MDF
- Glass

Options

- Webcam 
 - Ykiosk Software
- (Other options available upon request)

► The dimensions and specifications are given in graphical representation and may not correspond to the reality of the equipment. The dimensions shown are approximate and represent the equipment for a certain size display. The final dimension may vary depending on the display model and other components used. The client must request a technical drawing for final validation (measures and specifications).

Technical Drawing

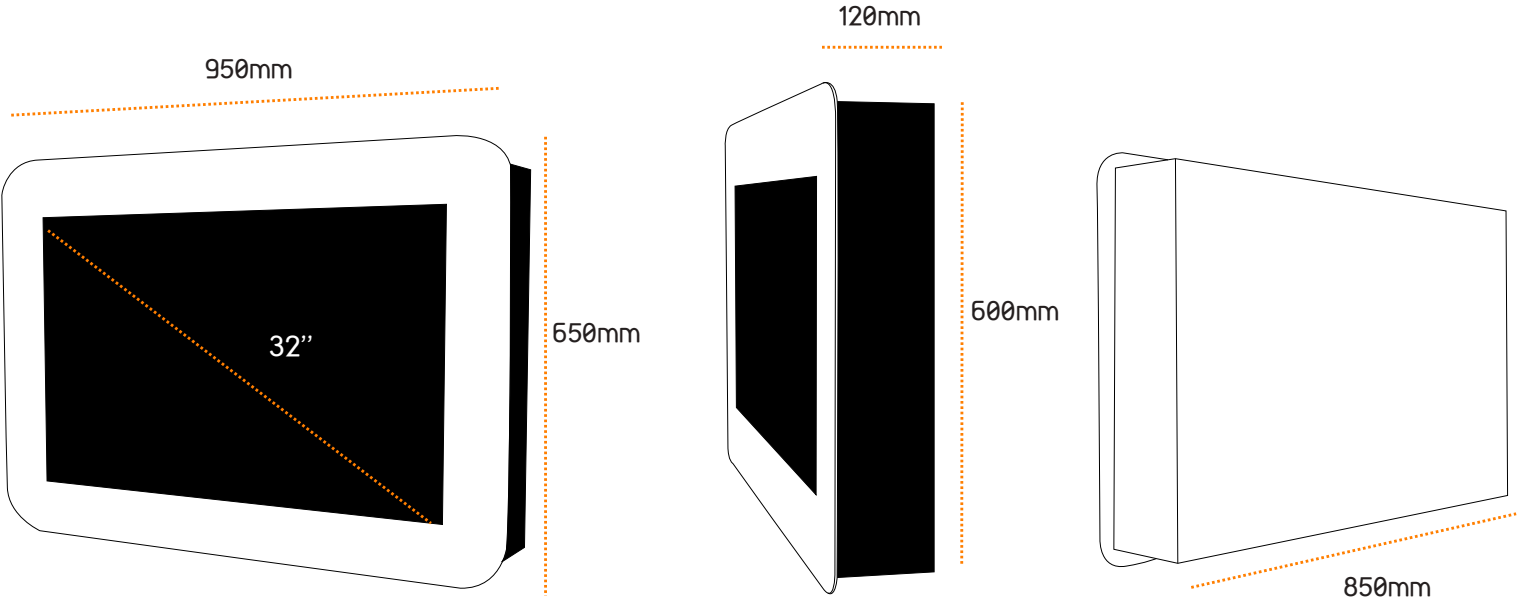

► The dimensions and specifications are given in graphical representation and may not correspond to the reality of the equipment. The dimensions shown are approximate and represent the equipment for a certain size display. The final dimension may vary depending on the display model and other components used. The client must request technical drawing for final validation (measures and specifications).

StyloW

Kiosk measures

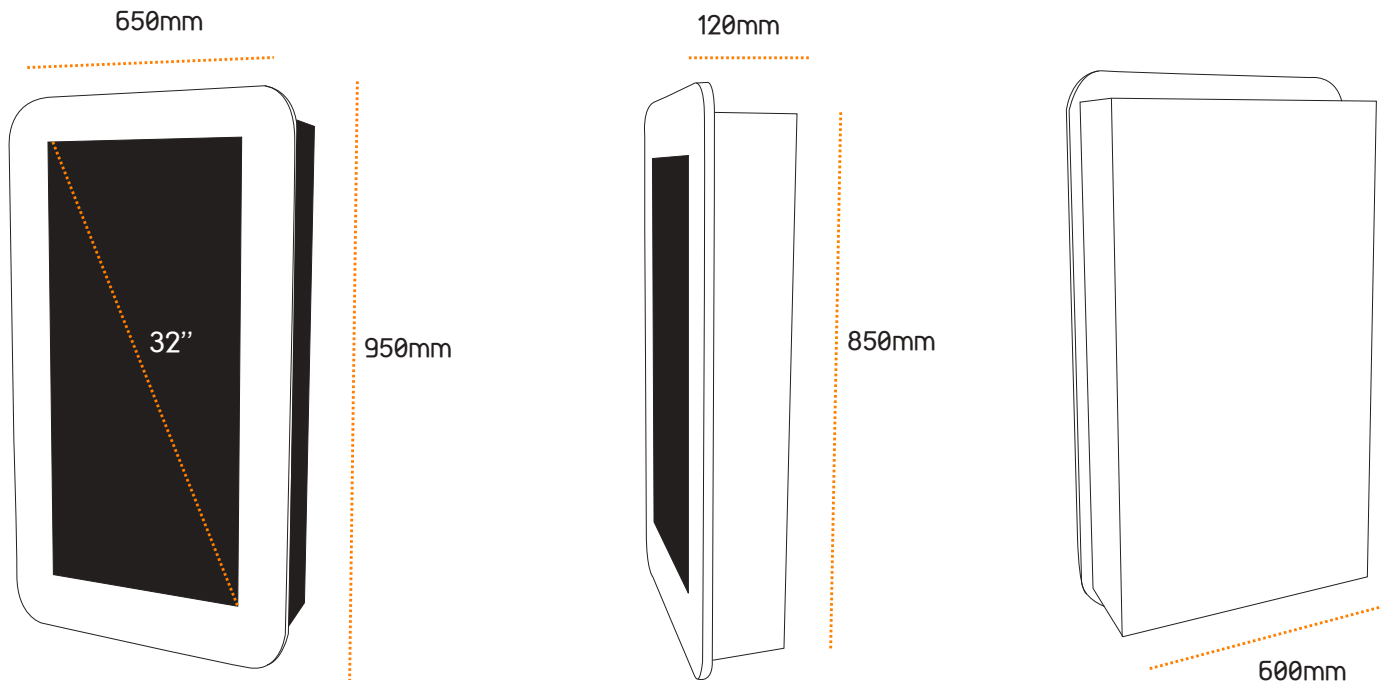

► The dimensions and specifications are given in graphical representation and may not correspond to the reality of the equipment. The dimensions shown are approximate and represent the equipment for a certain size display. The final dimension may vary depending on the display model and other components used. The client must request a technical drawing for final validation (measures and specifications).

Configuration

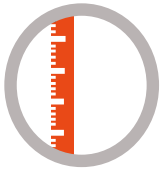

H 550 W 950 D 120mm
(for 32" display)



Displays to 22" a 103"
(resolution 1280x 1024 to 1920 x 1080 px)



Weight 20 Kg
(for 32" display)



Steel plate of 1,5mm/2mm



Integrated speakers



Stainless steel AISI304 or painted steel (RAL Colors) or glass

OPTIONAL



22" to 103" Displays



Touch screen
(SAW, Infrared, ProCap)



Atom, Dual Core, Core i3 or i5 PC computer



Wireless - WLAN



Windows 7 or 8, Linux, Mac *



Bluetooth



Ykiosk software (secure shell & browser)



Webcam

Other components can be integrated changing kiosk dimensions: ticket printer, coin validator, bill validator, card readers, antivandalic keyboard, proximity sensor, etc.

* depending on type of touch technology used

► The dimensions and specifications are given in graphical representation and may not correspond to the reality of the equipment. The dimensions shown are approximate and represent the equipment for a certain size display. The final dimension may vary depending on display model and other components used. The client must request technical drawing for final validation (measures and specifications).

Multimedia **kiosks**

Touch... the sky

This document is provided only for information purposes. The presented information is subject to change without prior notice, given the constant evolution of content. THE PARTTEAM GROUP is not responsible for any errors or omissions in this document, based on the information it contains, as a result of its publication.



oemKIOSKS | Partteam Group Portugal | Rua Nova da Nespereira, Pavilhão 10 | 4770 -287 Lagoa - Vila Nova de Famalicão
tel: +351 252 378 589 | +351 252 327 185 | fax: + 351 252 378 591 | Portugal
www.oemkiosks.com | oem@oemkiosks.com