

# Lex Kiosk

## Datasheet

Welcome to oemKIOSKS



---

Touch...The Sky



# Lex Kiosk

Robust & security for outdoor

The Lex model was designed specially for outdoor applications.

This model can be manufactured in stainless steel or painted steel (available in all RAL colors) using steel plate of 1,5mm to 2,5mm which ensures the stability and rigidity of the all structure.

This Kiosk is designed specially for information and/or multimedia advertising purposes.

The upper part of the Kiosk can have a space for illuminated advertising, protected by a glass/acrylic with the same curvature as the Kiosk and designed for easy replacement of the advertising.

The area where computer is installed and possible peripherals (card readers, coin acceptors, etc.), is protected with access through a security lock and includes a base with three power plugs.

One of the main characteristics of these kiosks is its design that allows integrating a large number of peripheral devices (card readers, tickets printer, coin acceptors, etc.) without having to redesign large pieces which gives this model great versatility and increases the applications field.

The Lex Model can be equipped with a Atom CPU with a 160 GB hard drive, 1 Gb Ram Memory, a 128Mb graphic card and a 10/100 mb ethernet, and Windows 7 Starter.

This kiosk can be produced with glass protection (top and 2 laterals) for outdoor environments.

## Technical Specifications Lex Kiosk

Dimensions: H2100 x W630 x D250  
Weight: aprox. 120 Kg.



# Lex

Distance comparison and main features

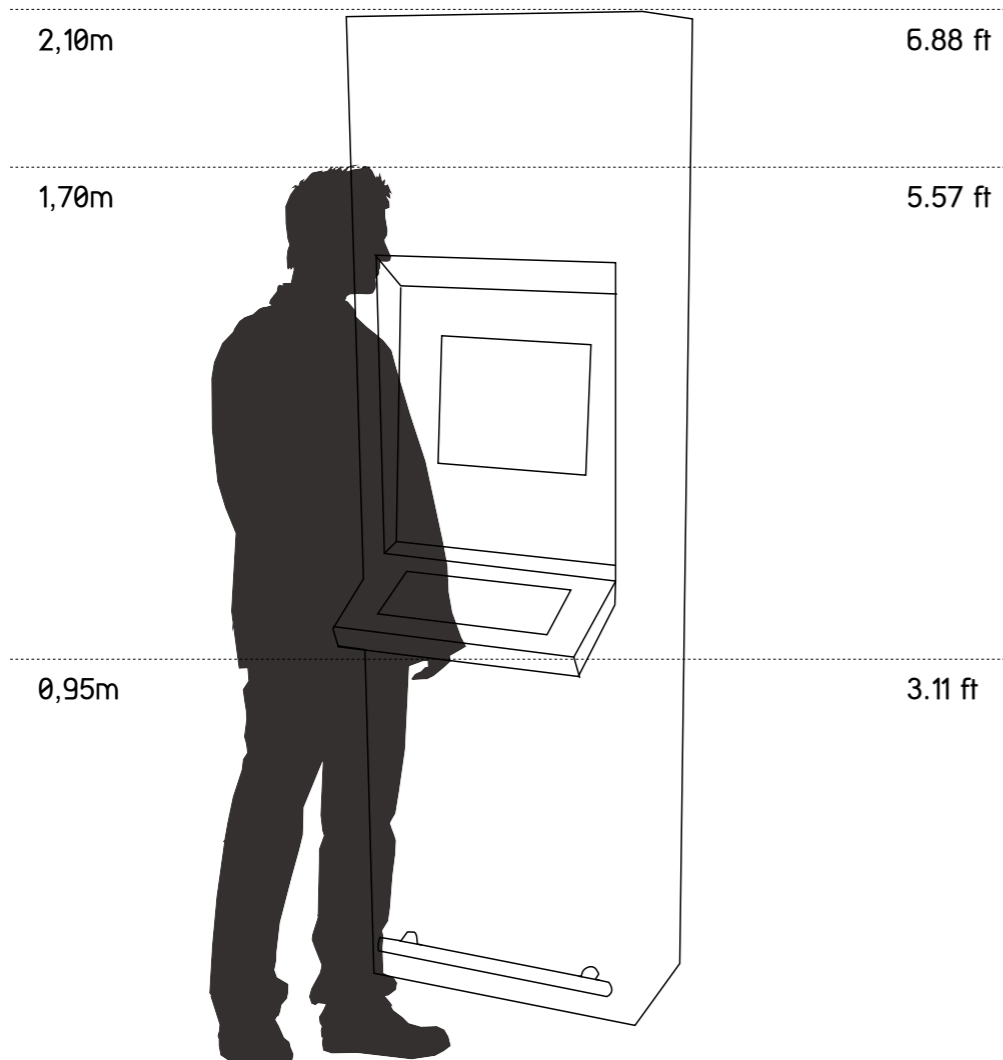

## Type

Indoor

## Materials

Painted Steel

Stainless Steel

## Options

Webcam

Ticket Printer

Card Reader

Antivandalic Keyboard

Bar Code Scanner

Handset Phone

Coin Validator

Bill Validator

Ykiosk Software

Protection Glass



# Lex

Kiosk measures

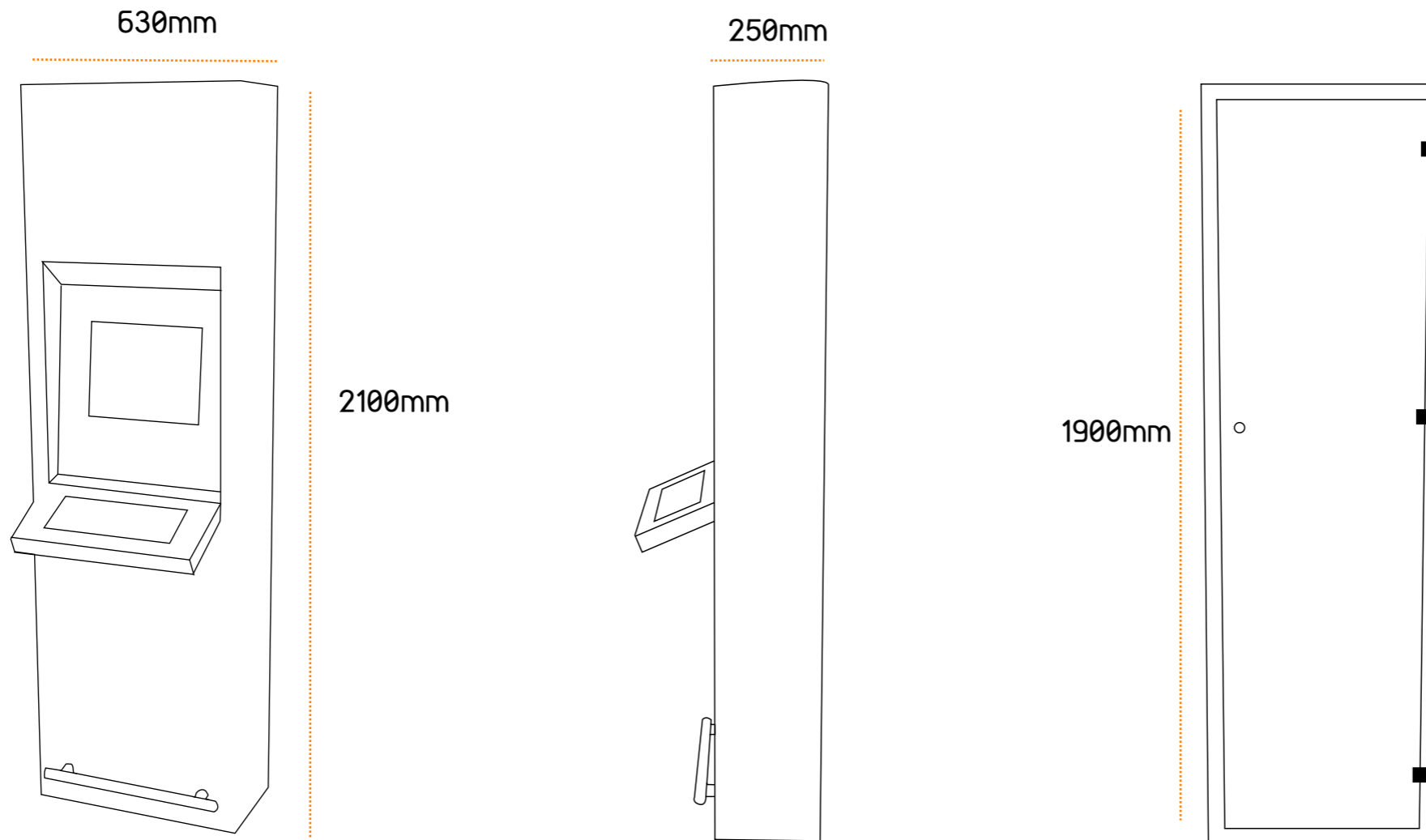

# Lex

## Technical data

---

### Dimensions:

- 17" Display (resolution: 1280 x 1024 Pixel)
- H2100 W630 D250

### Weight:

120 kg

### Configuration:

- Robust & Security for Outdoor
- Stainless steel AISI304 or painted steel (RAL Colors)
- Steel plate of 1,5mm to 2,5mm
- Antivandalic keyboard
- 17" XGA touchscreen display (resistive)
- Integrated speakers

### Optional:

- 19" to 24" Displays
- Atom or Dual Core PC computer
- Microsoft Windows 7 Professional
- Ykiosk software package
- Touch screen (SAW - antivandalism)
- Wireless networking - WLAN
- Bluetooth functionality
- Webcam

• Other components can be integrated changing kiosk dimensions: ticket printer, coin validator, bill validator, card readers, antivandalic keyboard, proximity sensor, etc.

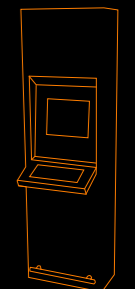

# oemKIOSKS | Your white label kiosk company

This document is provided only for information purposes. The presented information is subject to change without prior notice, given the constant evolution of content.  
THE PARTTEAM GROUP is not responsible for any errors or omissions in this document, based on the information it contains, as a result of its publication.



oemKIOSKS | Partteam Group Portugal | Rua Nova da Nespereira, Pavilhão 10 | 4770 -287 Lagoa - Vila Nova de Famalicão  
tel: +351 252 378 589 | +351 252 327 185 | fax: + 351 252 378 591 | Portugal  
[www.oemkiosks.com](http://www.oemkiosks.com) | [oem@oemkiosks.com](mailto:oem@oemkiosks.com)